

Series PCS Softstarter Intelligent Controller

**Three unique
softstarting modes**

**Controls motors to
400HP (@480V)**

**Built-in overload and
SCR bypass**

**Self diagnostic
capabilities**

Easy Set-up

Digital rotary switches quickly and easily set exact value. LED indication of all faults.

Line or Delta Compatible

The PCS is capable of running a 3-wire or 6-wire motor via a DIP switch setting.

Built-in Overload Protection

Electronic overload protection with selectable trip class. Overload trip class selection includes OFF, 10, 15 or 20 seconds. Manual or automatic trip reset.

Bypass Contactor

Bypass contactor on each phase. Once the motor is up to speed, the load is removed from the SCRs.

Over Temperature Protection

Internal thermistors monitor the SCR junction temperature. If overheated, microcomputer switches off the PCS and a TEMP fault is indicated via LED.

Phase Reversal Protection

When enabled via a DIP-switch, 3-phase input power will be verified before starting, ensuring the motor rotates in the same direction.

Phase Loss / Open Load

Automatic protection from motor burnout during single phase starting.

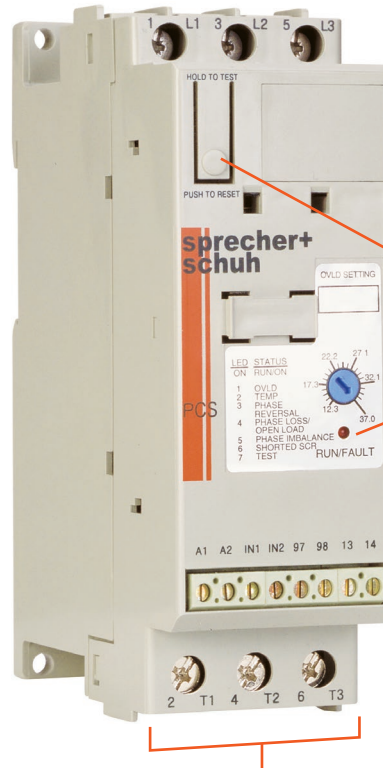

As little as 45mm (1-3/4") wide
(PCS 3...37 Amp)

Phase Imbalance

The unit monitors for imbalance between phase currents. Tripping occurs when the difference between the minimum phase current and the maximum phase current exceeds 65% for 3 seconds, and a fault will be indicated.

Shorted SCR

Prior to every start and during starting, the unit will check all SCRs for shorts and unit load connections to the motor.

Push to Test Function

The unit with control wiring can be tested for fault conditions or reset.

Fault Diagnostics

Faults indicated by blinking LED

- Overload
- Overtemperature
- Phase Reversal
- Phase Loss/Open Load
- Phase Imbalance
- Shorted SCR
- Test

Auxiliary Contacts

The PCS is equipped with an internal NO auxiliary contact. Additional 1 or 2-pole auxiliary contacts can be snapped on the right side.

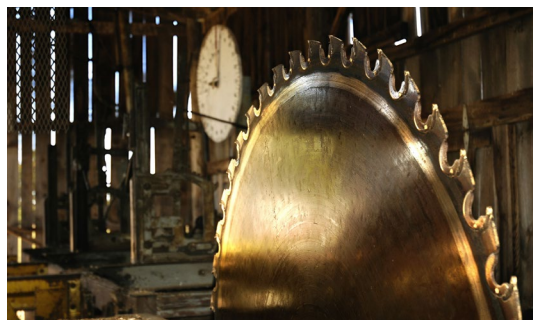
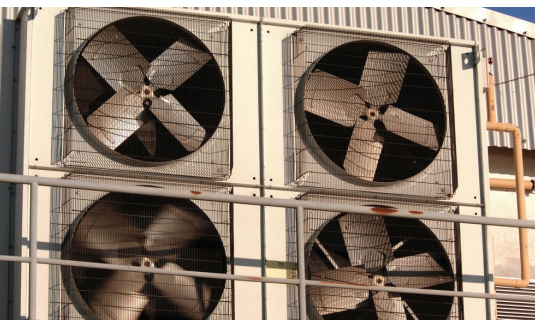

The PCS Softstarter Controller is one of the newest members of Sprecher + Schuh's broad line of softstarters. This DIN-rail or panel mounted unit provides three different soft starting modes for a variety of industrial applications including compressors, fans, lifts, chillers, conveyors and many applications where three phase motors are present.

The new PCS softstarter also includes a unique "soft stopping" mode for bringing loads to a controlled slow stop. This is useful in applications where spillage or tipping could occur without controlled deceleration.

Series PCS Features

Compact Design in Five Frame Sizes

Controller	Dimensions (mm)			DIN-rail mount	Panel mount
	A	B	C		
PCS-003...037	44.8	139.7	100	✓	✓
PCS-043...085	72	206	130	✓	✓
PCS-108...135	196.4	443.7	205.2	✓	✓
PCS-201...251	225	560	265.3	✓	✓
PCS-317...480	290	600	298	✓	✓

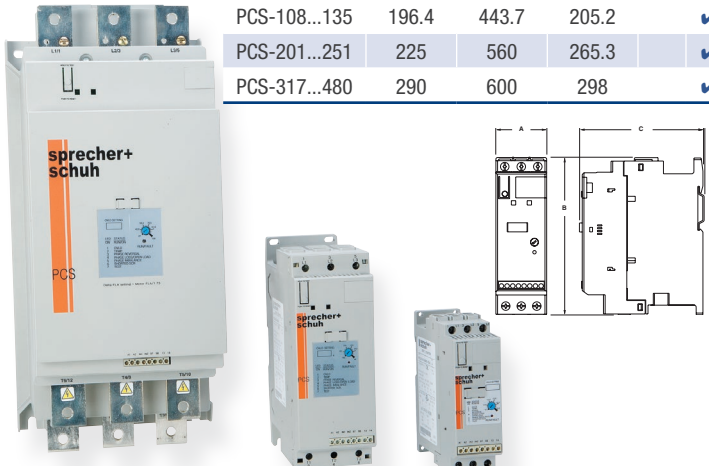

108...480A 43...85A 3...37A

PCS Selected Technical Data

Maximum Horsepower Three Phase ②				Current Rating	Overload Adjustment Range	With 100...240V AC Control Voltage ①
200V	230V	460V	575V			
200...600V AC Max. Applications						
0.5	0.5	1.5	2	3	1...3	PCS-003-600V
2	2	5	7.5	9	3...9	PCS-009-600V
3	5	10	10	16	5.3...16	PCS-016-600V
5	5	10	15	19	6.3...19	PCS-019-600V
7.5	7.5	15	20	25	8.3...25	PCS-025-600V
7.5	10	20	25	30	10...30	PCS-030-600V
10	10	25	30	37	12.3...37	PCS-037-600V
10	15	30	40	43	14.3...43	PCS-043-600V
15	20	40	50	60	20...60	PCS-060-600V
25	30	60	75	85	28.3...85	PCS-085-600V
30	40	75	100	108	27...108	PCS-108-600V
40	50	100	125	135	34...135	PCS-135-600V
60	75	150	200	201	67...201	PCS-201-600V
75	100	200	250	251	84...251	PCS-251-600V
100	125	250	300	317	106...317	PCS-317-600V
125	150	300	350	361	120...361	PCS-361-600V
150	200	400	500	480	160...480	PCS-480-600V

- ① For units with 24V AC/DC Control Voltage add "-024" to end of Catalog Number.
- ② See Sprecher+Schuh catalog for Wye-Delta HP ratings.

Line & Delta Connection

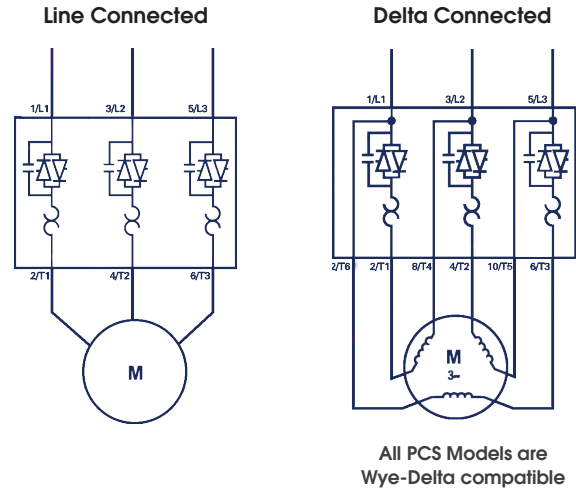

Four Modes of Operation

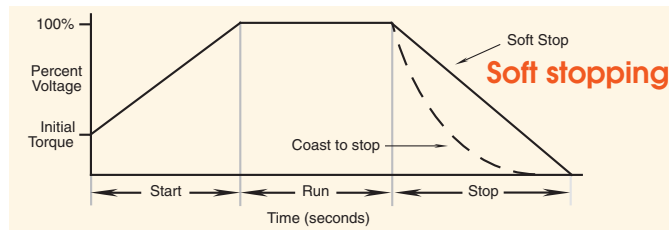
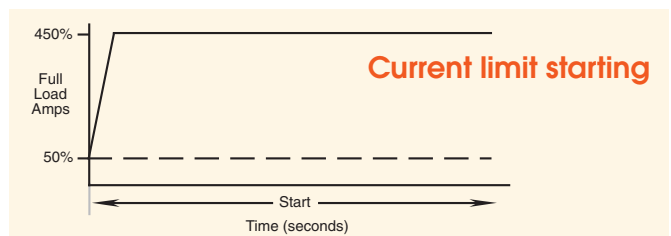
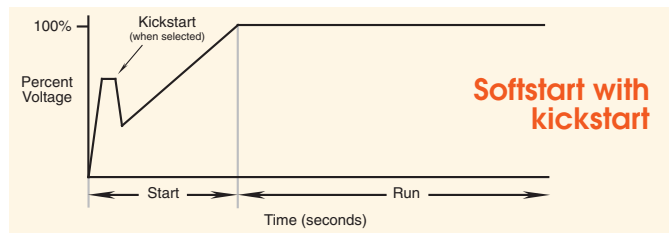
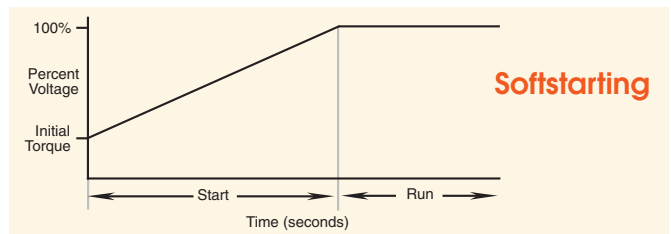

See Sprecher + Schuh's general catalog for complete information and pricing on PCS softstarter controllers.