

# Remote Reset and Thermistor Protection

## Overload Relay Protection Modules

The CEP7-EPT is a side-mounted device designed to provide increased motor protection by interrupting the change in PTC resistance. This provides added protection in situations involving obstructed cooling path and high ambient temperature which would not be detected simply by monitoring current.



## Protecting Your Motor from Thermal Overheating

Electric motors represent a significant investment and losing them to overheating in a process critical application is just not an option. Positive Temperature Coefficient resistors are often installed in the stator windings of the motor to sense the motor temperature. A PTC resistor, otherwise known as a thermistor, increases its resistance with an increase in temperature. The average overload relay does not accept the signal from one or a chain of up to six thermistors.

A high temperature trip occurs when resistance reaches 3400 ohms. This side mount module detects a PTC chain short circuit when resistance drops to less than 20 ohms as well as a PTC open circuit when resistance jumps to 20K ohms. If down time means loss of production then you shouldn't be without thermistors in your motor and a CEP7-EPT to provide that extra measure of protection from thermal damage to your motors.



# Thermistor PTC Protection Module

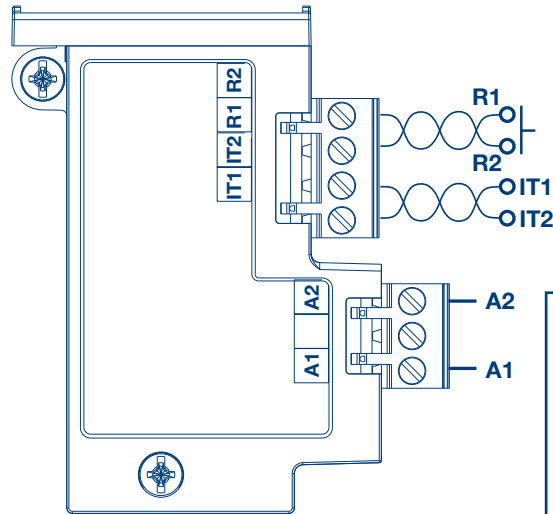

- Apply 24 - 240V, 47 - 63HZ or DC to terminals A1 and A2 for control power.
- Connect remote reset pilot device to Terminals R1 and R2
- Connect Terminal IT1 and IT2 to PTC Chain

Overload Relay and PTC Reset Mode	PTC Protection	Overload Relay Type
SW1	SW2	SW3
Manual: 1	Enable: 1	3 Phase: 1
Automatic: 0	Disable: 0	1 Phase: 0

PTC Protection and LED Status indication	
• Type of Control Unit	Mark A
• Number of Sensors	6
• Maximum Cold Resistance of Sensor Chain	1500 $\Omega$
• Trip Resistance	3400 $\Omega \pm 150 \Omega$
• Reset Resistance	1600 $\Omega \pm 50 \Omega$
• Short Circuit Trip Resistance	25 $\Omega \pm 10 \Omega$
• Open Circuit Trip Resistance	> 20,000 $\Omega$
• Maximum Voltage at 1T1 / 1T2 (R <sub>ptc</sub> =4k)	< 7.5 Vdc
• Maximum Voltage at 1T1 / 1T2 (R <sub>ptc</sub> =open)	< 30 Vdc
• PTC Response Time	500ms...800ms

**Provision for reset after trip from remote pilot device**

CEP7-EPT Operational LED	
Status LED:	<b>Steady Green</b> - Module is powered up.
	<b>Flashing LED</b> - The number of flashes followed by a pause identifies the specific trip code as follows:
	(1) Flash - overload trip
	(2) Flash - phase loss trip
	(3) Flash - PTC trip
	(4) Flash - PTC open circuit
(5) Flash - PTC short circuit	
	<b>Fast Flash</b> - Impending trip PTC Thermistor fault detected and CEP7 not yet capable of tripping.
	<b>Steady Red</b> - Hardware fault. Internal hardware fault detected and CEP7 trip attempted.



## CEP7-ERID VALUE KITS

Intelli-buttons and your choice of the side-mounted modules can be ordered as (a) individual components, (b) the combination of necessary parts can be ordered as a kit or (c) you can have these kits installed in any control panel built by Sprecher + Schuh that contains a CEP7-EE\_ overload relay. Check out our Intelli-button flyer for the Value Kit ordering details.